



# CBL 6111D BILOG® ANTENNA 30 MHz to 1 GHz



CBL 6111D vertical onto tripod  
BTP 6020A

- Ideal for compliance emission testing
- One antenna - one sweep
- Saves up to 30% test time
- Excellent symmetry
- Common carrier shippable

### The 'Classic' BiLog® Antenna

The CBL 6111D is a high performance ultra wideband BiLog® antenna for emission and immunity EMC testing. This is the original 'classic' BiLog® combining two antennas in one, making savings of at least 20 - 30% on test time and reducing measurement errors due to cable and connector wear.

### Optimized for Emission Measurements

The CBL 6111D has been accepted worldwide for emission measurements. The CBL 6111D, although used primarily as an emission measuring antenna, can handle CW powers up to 300 watts, making it suitable for most immunity measurements requiring fields up to 10 V/m, or even greater. The CBL 6111D is linearly polarized and exhibits excellent balance (< 1 dB) and cross polarization performance (> 20 dB).

### Technical specifications

Frequency range:	30 MHz to 1 GHz
Typical gain:	5 dB
Impedance (nominal):	50 Ω
Maximum continuous power:	300 W
Connector:	N type female
VSWR:	Average 2:1
Size antenna (L x H x W in mm):	approx. 1310 X 1390 X 630 (see drawing)
Weight:	approx. 3.5 kg
Recommended tripod:	BTP 6020A

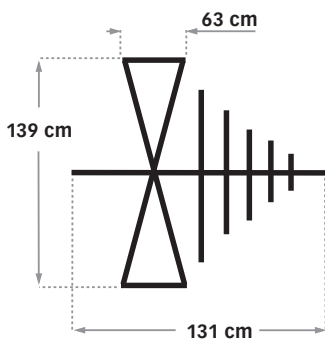

### Typical E field polar patterns for - - 30, — 300, ···· 650 and - - - 1000 MHz

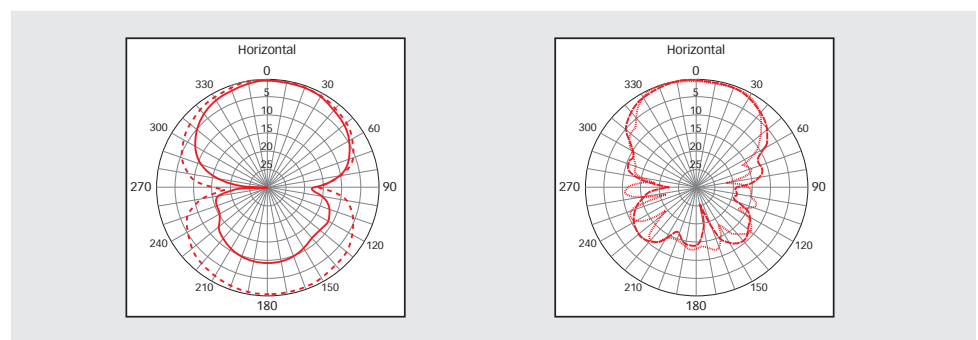

Advanced Test Solutions for EMC

# CBL 6111D BILOG<sup>®</sup> ANTENNA 30 MHz to 1 GHz

Typical VSWR

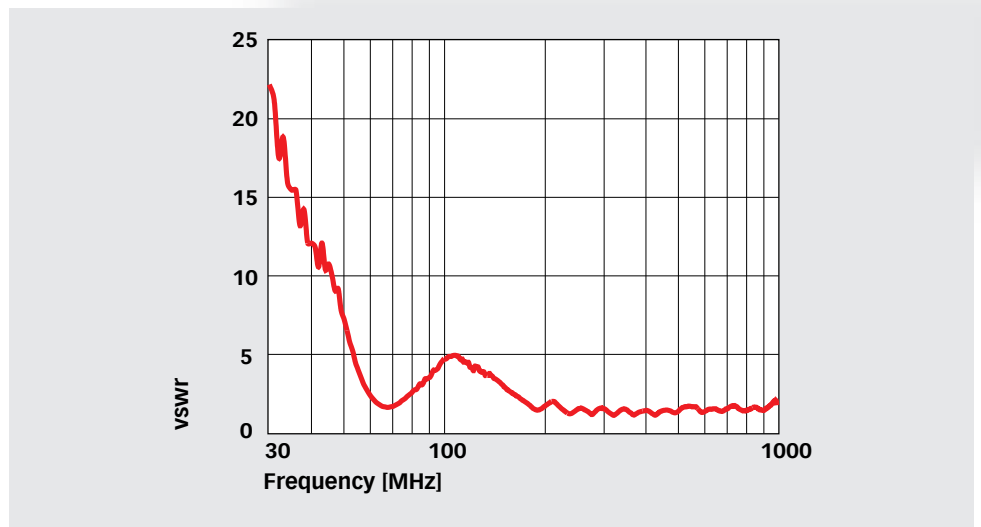

Typical drive power for 10 V/m at 3 m, - - - CW power, — power with 80% modulation

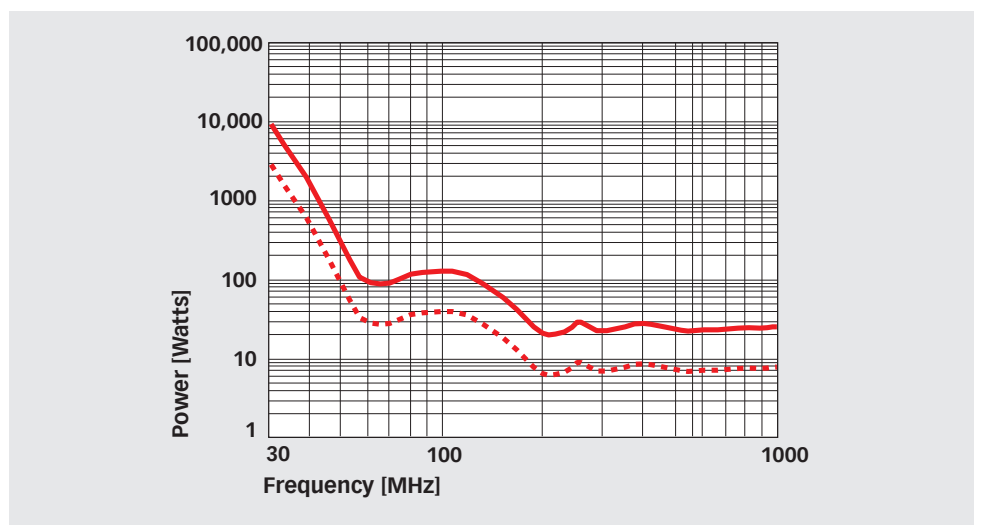



# **CBL 6111D** **BILOG® ANTENNA 30 MHz to 1 GHz**



Typical antenna factor

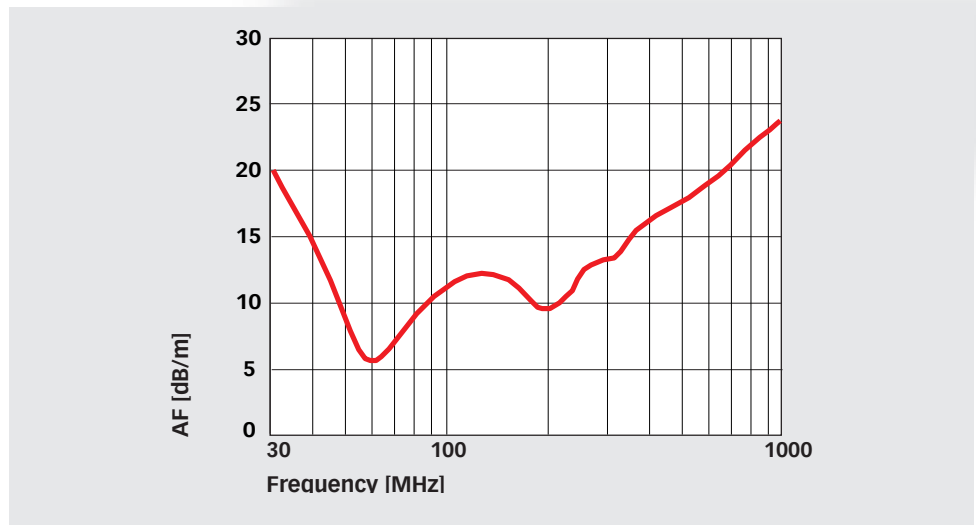

Typical gain

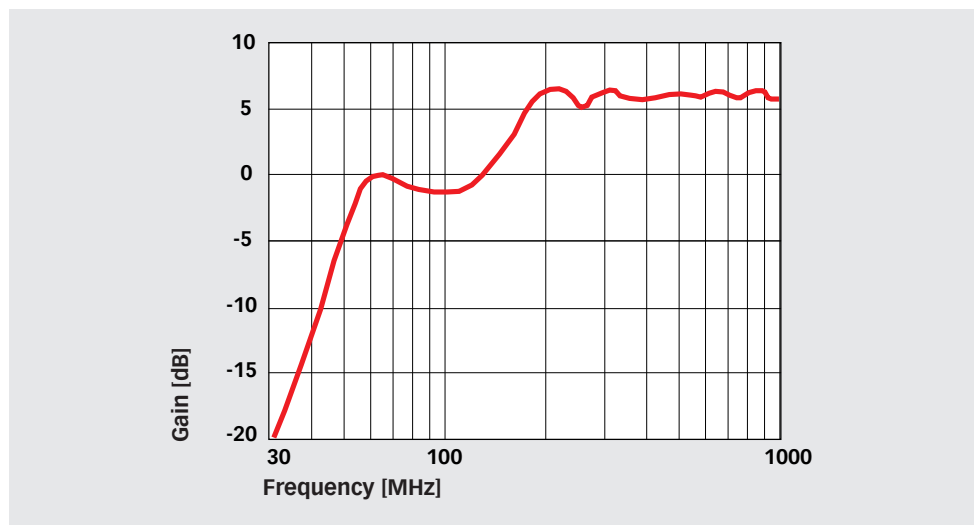

# **CBL 6111D** **BILOG® ANTENNA 30 MHz to 1 GHz**

Typical gain ratio

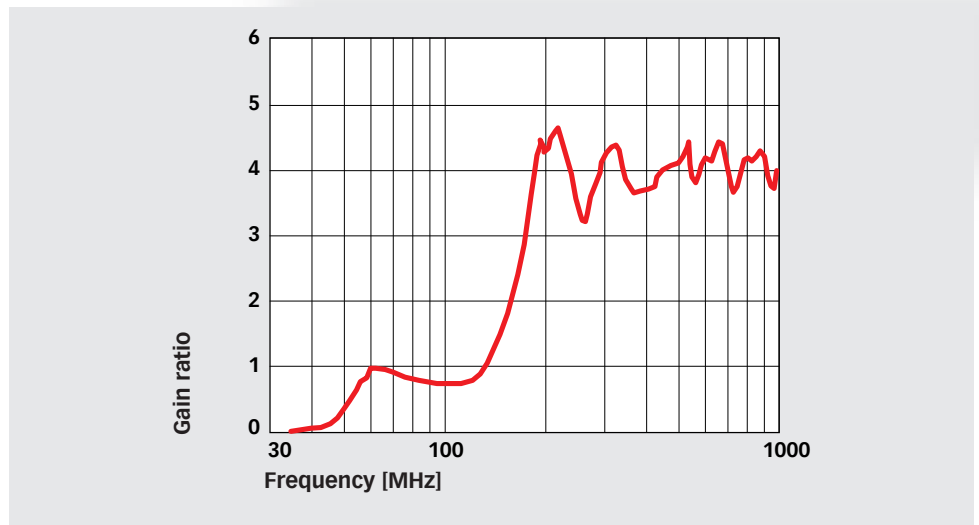

Typical cross polarisation

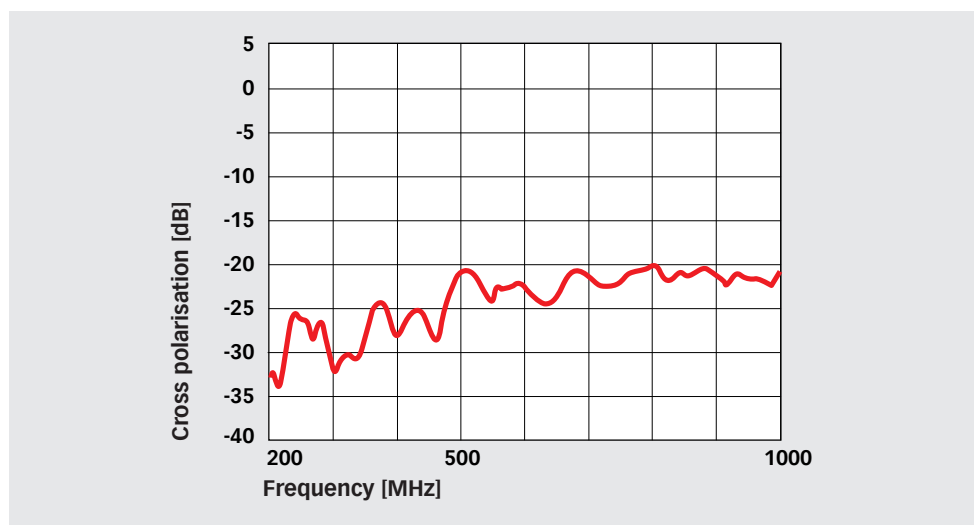



# CBL 6111D BILOG® ANTENNA 30 MHz to 1 GHz

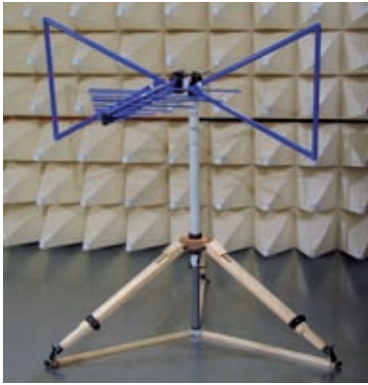

CBL 6111D horizontal onto tripod  
BTP 6020A

### Typical balance

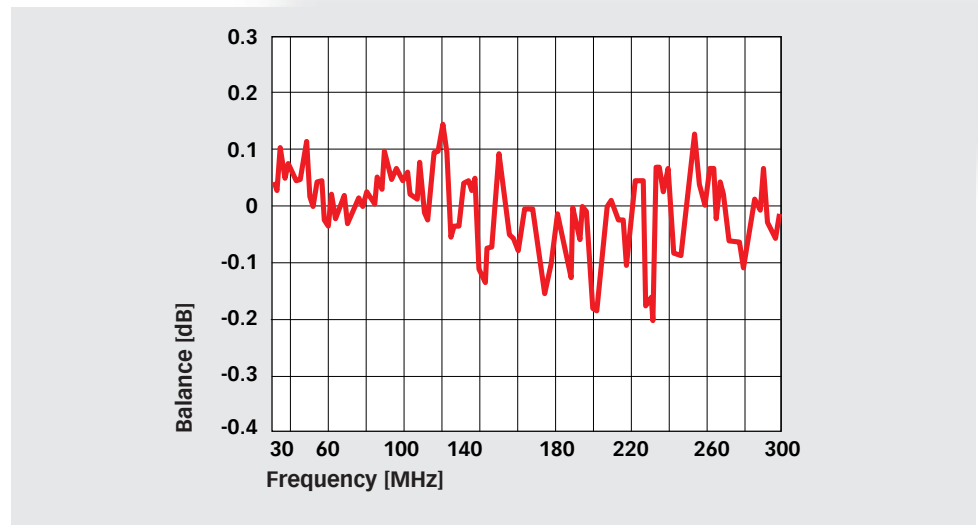

### Delivery information

Part number	Description
346-000	CBL 6111D BiLog antenna 30 MHz - 1 GHz
97-244570	Ant Cert-TC Traceable calibration (ISO17025), order only with the antenna, free space calibration (horizontal), other calibrations on request
248504	BTP 6020A-0880 EMC Tripod with tube 880 mm and mounting head for antennas with 22 mm tube
248505	BTP 6020A-0680 EMC Tripod with tube 680 mm and mounting head for antennas with 22 mm tube
248523	BTP 6020A-1370 EMC Tripod with tube 1370 mm and mounting head for antennas with 22 mm tube
346-199	MTC 9011 Metal transit case for CBL 6111, 6112, 6141 or 6143